

Step-by-step interpretation of 10-day electronic temperature monitoring devices for international vaccine shipments

Q-tag[®] 2plus



REVISION HISTORY		
Date	Reason	Approved by
29 January 2007	Final version issued for comments.	Ü. Kartoğlu
2 February 2007	Reissued with comments incorporated from UNICEF SD and with inclusion of Alarm Reporting Form.	Ü. Kartoğlu
7 March 2007	English copy editing	Ü. Kartoğlu
27 December 2007	Removal of Spytemp from the document	Ü. Kartoğlu
17 January 2009	Removal of 3M TX from the document	Ü. Kartoğlu

INTRODUCTION

According to WHO *Guidelines on the international packaging and shipping of vaccines* (WHO/IVB/05.23) a 10-day electronic temperature monitoring device should be included in each international vaccine shipping carton¹.

10-day electronic temperature monitoring devices show when, and to what extent, the set temperature conditions have been violated. There are two different types of devices.



Type I device with YELLOW backing card

Type I device accompanies the DTP, DT, TT, Td, HepB, IPV, liquid Hib and combination vaccines, with the following temperature alarm settings:

Temperature	Alarm type	Period for triggering the alarm
$\geq 45^{\circ}\text{C}$	single event	1 hour
$\geq 30^{\circ}\text{C}$	Cumulative	10 hours
$\leq -0.5^{\circ}\text{C}$	single event	1 hour

Type II device with BLUE backing card

Type II device accompanies the OPV and freeze-dried BCG, measles, MR, MMR, lyophilized Hib, yellow fever and meningitis vaccines, with the following temperature alarm settings:

Temperature	Alarm type	Period for triggering the alarm
$\geq 45^{\circ}\text{C}$	single event	1 hour
$\geq 30^{\circ}\text{C}$	cumulative	10 hours
$\geq 10^{\circ}\text{C}$	cumulative	20 hours

If not stopped manually, the devices stop automatically when they reach a recording interval of 10 days.

¹ CCM will only be included in the case of dry ice being used as coolant (electronic temperature monitoring devices do not perform in extremely cold temperatures).

Standard backing cards, as described in the Performance, Quality and Safety (PQS) performance specification for electronic shipping indicators WHO/PQS/E06/TR07.1), are shown below. Backing cards come in three languages: English, French and Spanish. The colour code is set for the type of device, meaning that different language versions in Type 1 will all come in YELLOW.

The text enclosed in <arrow brackets> will be replaced with the appropriate product-specific name or description.

**Type 1 – on light yellow card
Front face**

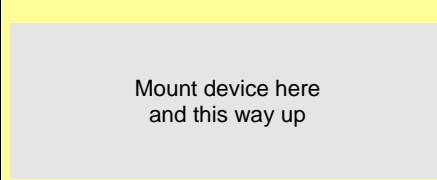
 <p>Mount device here and this way up</p>
<p>Use only for DTP, TT, DT, Td, HepB, IPV, liquid Hib and combination vaccines.</p>
<p style="text-align: center;">SENDER</p> <ol style="list-style-type: none"> 1. Prepare the shipping container. 2. Break off the twin label with bar code and stick it onto the shipping documents. 3. Activate <DEVICE NAME> by <describe activation procedure for device> with a start delay of 1 hour. 4. Complete the card below in ballpoint pen. 5. Insert this card, with the activated device attached, into the shipping container. 6. Seal the shipping container. <p>Supplier name: _____</p> <p>Date: _____ Time: _____ dd:mm:yyyy hh:mm</p> <p>Vaccine PO number: _____</p> <p>Vaccine: _____</p> <p>RECEIVER: please turn the card! ⇒⇒</p>

**Type 2 – on pale blue card
Front face**

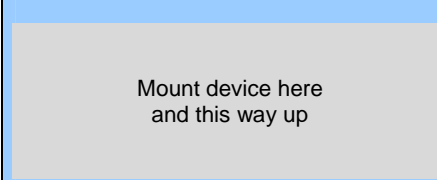
 <p>Mount device here and this way up</p>
<p>Use only for OPV, freeze-dried BCG, measles, MR, MMR, Hib, yellow fever and meningitis vaccines.</p>
<p style="text-align: center;">SENDER</p> <ol style="list-style-type: none"> 1. Prepare the shipping container. 2. Break off the twin label with bar code and stick it onto the shipping documents. 3. Activate <DEVICE NAME> by <describe activation procedure for device> with a start delay of 1 hour. 4. Complete the card below in ballpoint pen. 5. Insert this card, with the activated device attached, into the shipping container. 6. Seal the shipping container. <p>Supplier name: _____</p> <p>Date: _____ Time: _____ dd:mm:yyyy hh:mm</p> <p>Vaccine PO number: _____</p> <p>Vaccine: _____</p> <p>RECEIVER: please turn the card! ⇒⇒</p>

BACK FACE (English)

Type 1 - Back face

RECEIVER	
1. On arrival, remove <DEVICE NAME> from the shipping container immediately. 2. <Describe stop procedure for device>. 3. Read the LCD display and follow the instructions as described below.	
OK DISPLAY	
<clearly illustrate OK screen display> If OK, use vaccines normally.	
ALARM DISPLAY	
<clearly illustrate alarm screen display>	
If <DEVICE NAME> displays an alarm, please proceed according to the decision table below:	
Alarm temperature	What to do with vaccines:
>= 45° C	Contact procurement agency
>= 30° C	Contact procurement agency
<= -0.5° C	Conduct shake test. Use vaccines if passes. Inform procurement agency of test result.
Assembled and distributed by [company name and web address]	

Type 2 - Back face



RECEIVER		
1. On arrival, remove <DEVICE NAME> from the shipping container immediately. 2. <Describe stop procedure for device>. 3. Read the LCD display and follow the instructions as described below.		
OK DISPLAY		
<clearly illustrate OK screen display> If OK, use vaccines normally.		
ALARM DISPLAY		
<clearly illustrate alarm screen display>		
If <DEVICE NAME> displays an alarm, please proceed according to the decision table below:		
Alarm temperature	What to do with vaccines:	
	OPV only	Other vaccines
>= 45° C	Contact procurement agency	Contact procurement agency
>= 30° C	Contact procurement agency	Contact procurement agency
>= 10° C	Contact procurement agency	Accept
Assembled and distributed by [company name and web address]		

This guide describes step-by-step what to do when you receive an international vaccine shipment.

REMOVING and STOPPING THE DEVICES

When you receive an international vaccine shipment, you must open ALL cartons to remove the devices. This has to be done one-by-one.

Each device has a bar code. Box number 1 should contain, along with shipping documents, a list of box numbers with the bar code\serial number of corresponding devices included in each box. When you open a box and remove the electronic device, you must also write down the box number on the backing card for easy reference.

STOPPING THE DEVICE
Open ALL shipping cartons and repeat the following steps for each electronic device:
<p style="text-align: center;">Q-tag® 2 plus</p>  <p>The image shows the Q-tag 2 plus screen in an 'OK' state. The screen displays a central digital clock showing '12:41'. Above the clock, it says 'OK'. To the left, there are temperature thresholds: '1h >= 45°C', '10h >= 30°C', and '1h <= -0.5°C'. Below these, it says '80-00-30-V2 stop'. To the right, it shows 'transport time' with a circular arrow and '10h', '30h', '40h' markers. At the bottom, it says 'Q-tag 2+ Temperature Monitor D= 60min'.</p>
PRESS the STOP button for 3 seconds. When stopped, run signal at the right bottom corner should disappear and stop sign should appear at the left bottom corner of the screen.
When stopped the screen looks as follows:
<p style="text-align: center;">Q-tag® 2 plus</p>  <p>The image shows the Q-tag 2 plus screen in an 'ALARM' state. The screen displays a central digital clock showing '08:27'. Above the clock, it says 'ALARM'. To the left, there are temperature thresholds: '1h >= 45°C', '10h >= 30°C', and '1h <= -0.5°C'. Below these, it says '80-00-30-V2 stop'. To the right, it shows 'transport time' with a circular arrow and '10h', '30h', '40h' markers. At the bottom, it says 'Q-tag 2+ Temperature Monitor D= 60min'.</p>
See stop sign on the left bottom corner of the screen.

After stopping the devices, you need to check the alarm status of each one.
The "OK" screen is displayed as follows:



OK sign is seen in the middle of the screen.

If there are any ALARMS the ALARM screen is displayed as follows:



ALARM sign is seen in the middle of the screen. ◀ symbol indicating the type of alarm also appears on the left side of the screen pointing to the types of alarms. The ◀ symbol closest to the left edge indicates the first alarm, while all later alarms are indicated in the "next" column.

If there are any alarms, write down the time you stopped the device on the backing card. This is important when you refer to the device after you stopped it. It will help you to calculate the precise time of violation.

Make a photocopy or scan the device to document the ALARM status. In each image, indicate the number of the box that the device was in.

Include all necessary information in the Vaccine Arrival Report (VAR).

If there are any ALARMS, fill in the Alarm Reporting Form and attach it to the VAR.

Send the VAR with photocopies or printed images from scanned devices and the Alarm Reporting Form to the "procurement agency".

On the following pages, you will find product-specific information regarding display of information and using the **HISTORY** mode to see details of temperature violations.

Q-tag® 2 plus

WHO/PQS/E06/02



The figure below describes the Q-tag® 2 plus device (in the figure the screen is displayed in TEST mode to show all features).

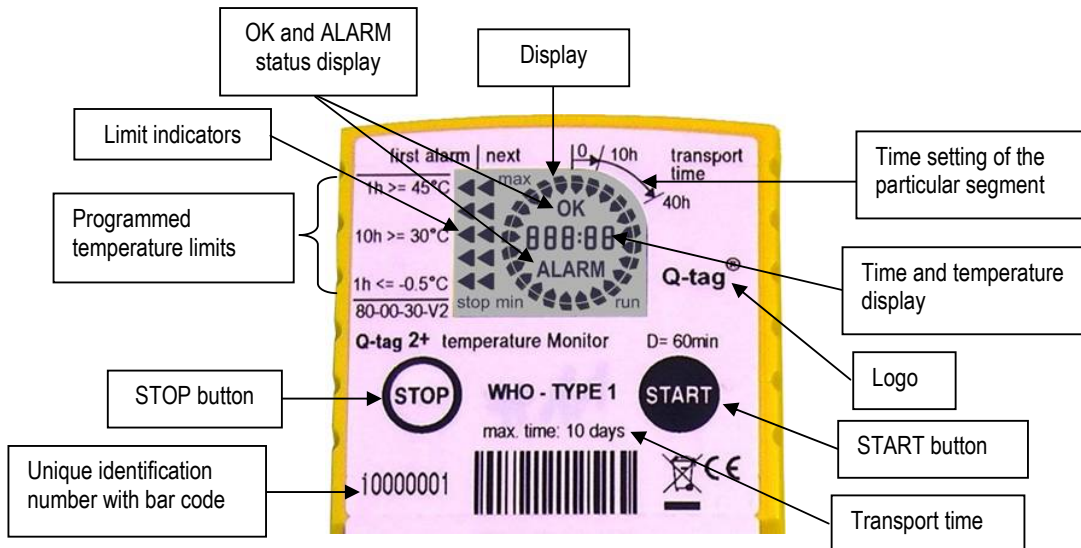

Display of the Q-tag® 2 plus:

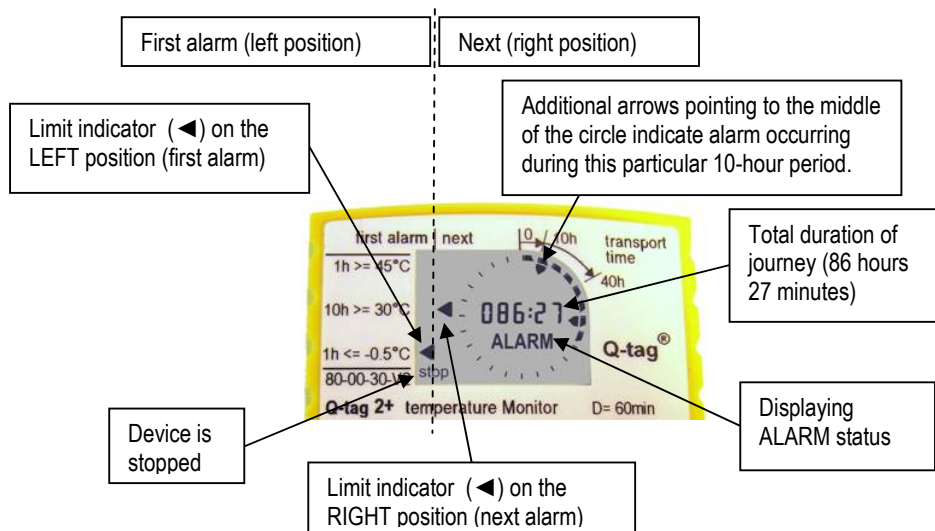

The circle segments give an indication of the elapsed transport time. One segment corresponds to 10 hours in PIS/E06/55 Q-tag® 2 plus. In this example eight visible segments are highlighted indicating that the device was activated for at least 80 hours. The device displays 86 hours 27 minutes as elapsed transport time (if the 10-hour block is not completed, the segment will not be highlighted).

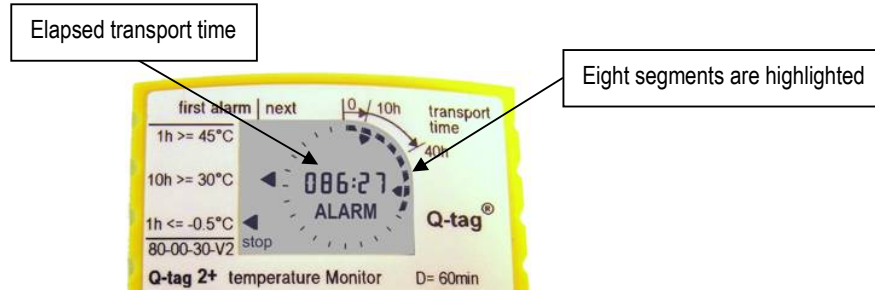

"OK" remains visible until any alarm is detected. It is then replaced by "ALARM" and more information is displayed.



In **ALARM** status, arrows inside the circle show in which time segments alarms occurred. Triangles (◀) on the left side of the display indicate the detected alarm types. These triangles are arranged in two columns. The triangle in the left column indicates the first detected alarm type, and all later alarm types are indicated in the right column. The definitions of the different alarm types are printed on the label to the left of the display.

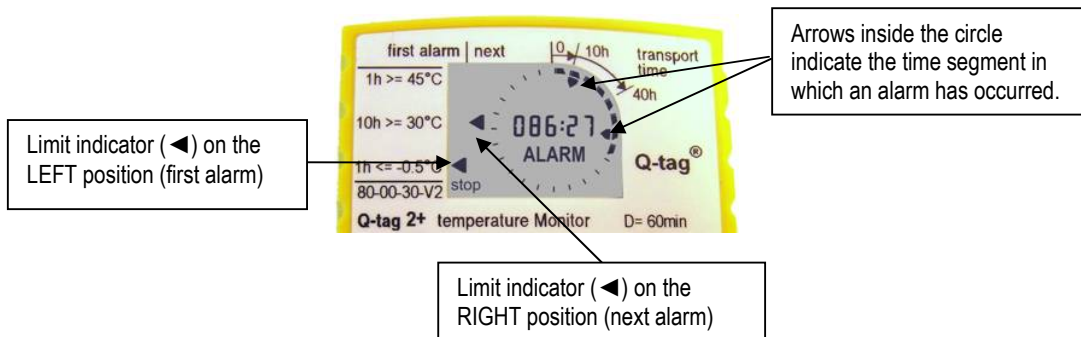

Step-by-step user guide for Q-tag® 2 plus

- Note that each shipping carton contains an electronic device, so you must open **ALL** boxes.

- Remove the Q-tag® 2 plus from the carton and press the **STOP** button for three seconds. The **run** sign will disappear from the bottom right corner of the screen and the **stop** sign will appear on the bottom left corner of the screen.

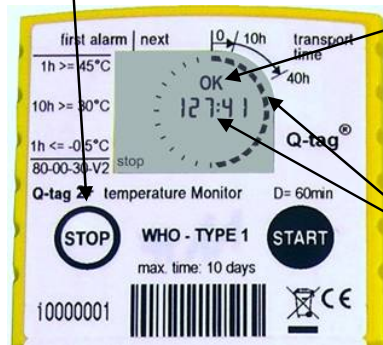

- Check the screen. If an **OK** sign is displayed, it means there were no temperature violations during the shipment.

- The number of dark segment marks indicates the total transport time. In this example, the shipment took at least 120 hours (12 dark segments are highlighted). Precise elapsed transport time displayed in the middle of the circle is 127 hours 41 minutes.

- Limit indicator (◀) on the left position indicates the first alarm. In this example, the first alarm is a violation of -0.5°C limit for more than one hour. This alarm occurred between 10 and 20 hours (corresponding to the second time segment after the activation of the device).



- If an **ALARM** sign is displayed, that shows temperature limits were violated during the shipment. Additional arrows pointing to the centre of the circle indicate the time periods in which alarms have occurred.

- If there are more limit indicators (◀) on the right position, this indicates additional alarms (second, third or fourth). Details can only be obtained in **HISTORY** mode.

8. All stored data can be retrieved for six months after stopping the Q-tag[®] 2 plus. The device must be set in the **HISTORY** mode. You activate this mode as follows.

- Press **START** button firmly.
- Simultaneously press **STOP** button for one second.
- Release both buttons.

9. As soon as **HISTORY** mode is activated, the **first time segment** and the **max** sign start **flashing**.

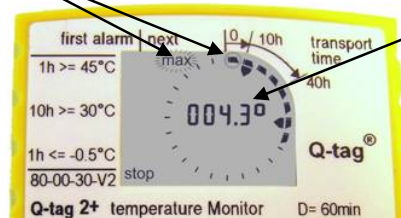

10. Additionally, a temperature is displayed in the LCD centre. This is the highest recorded temperature during the first time segment.

11. With the next push to **START** the **max** sign disappears and **min** sign flashes. First time segment continues **flashing**.

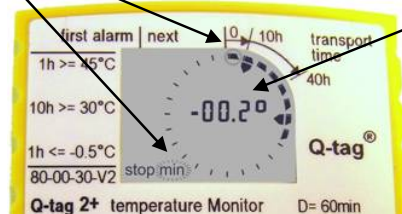

12. The temperature displayed in the LCD centre is the recorded minimum during the blinking time segment.

During **HISTORY** mode operation, the Q-tag[®] 2 plus automatically falls back to the **STOP** mode if the **START** button is not pressed again within 60 seconds, or immediately if the **STOP** button is pressed.

13. The next push to **START** shows the recorded mean temperature of the currently blinking time segment, accompanied by both flashing indicators **max** and **min**.
14. All following time segments can be read in the same way by subsequent pushes to the **START** button.

Important: No mean value is available for the last time segment.

Alarm details (HISTORY mode)

15. If alarms have been recorded, they will be indicated by arrows inside the segment circle. The alarm details are also visible in the **HISTORY** mode. In a segment with alarms, the maximum, minimum and mean temperatures are displayed as formerly described by repeatedly pressing the **START** button (maximum “**max**”, minimum “**min**”, and mean value “**max**” + “**min**”).

16. If there is an alarm, when pressing the **START** button for the fourth time, the **ALARM** sign appears in the middle of the screen.

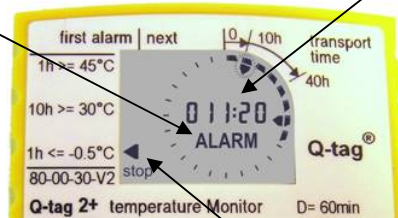

17. Above the **ALARM** sign, time display indicating the elapsed time between the start of measurements and the alarm event appears. In this example, at 11 hours 20 minutes -0.5°C alarm was triggered for more than one hour.

18. ◀ symbol in the left display region indicates the alarm type as printed on the label.

19. The next push to the **START** button gives details of the temperature recorded during the violation. For 10°C , 30°C , and 45°C alarms it displays the **highest** temperature recorded during the violation and this is indicated by the **max** sign flashing. For a -0.5°C alarm, it displays the **lowest** temperature recorded during the violation and the **min** sign starts flashing.



Since this alarm involves low temperatures, the **min** sign is flashing indicating that the temperature displayed is the minimum temperature recorded.

In this example the lower alarm is triggered. The lowest (minimum) temperature recorded during the violation was -4.2°C .

◀ symbol in the left display region indicates the alarm type as printed on the label.

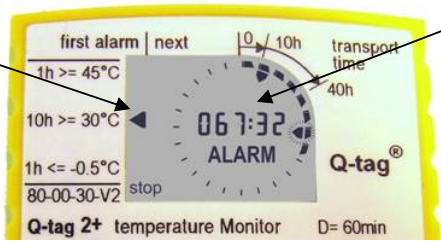

In this example, at 67 hours 32 minutes, the 30°C alarm was triggered for more than 10 hours.

Since this alarm involves high temperatures, the **max** sign is flashing indicating that the temperature displayed is the maximum temperature recorded.



With the next push to the **START** button, the screen in the middle displays the highest (maximum) temperature recorded during the violation which was 34.7°C.

20. Up to three alarms can be recorded per segment, and can easily be read as described above. After showing the last recorded alarm of any segment, with the next push to **START**, the display automatically jumps to the maximum temperature of the following segment.

How can Q-tag® 2 plus be tested? (TEST mode)

Q-tag® 2 plus has a **TEST** mode which can be used prior to starting and after stopping the device but not during active measurement. This mode is activated by firstly pressing and holding the **STOP** button, then simultaneously pressing **START**, and releasing both buttons. The display shows 10 times alternately the current ambient temperature and all display segments. **TEST** mode confirms that the device is working properly.

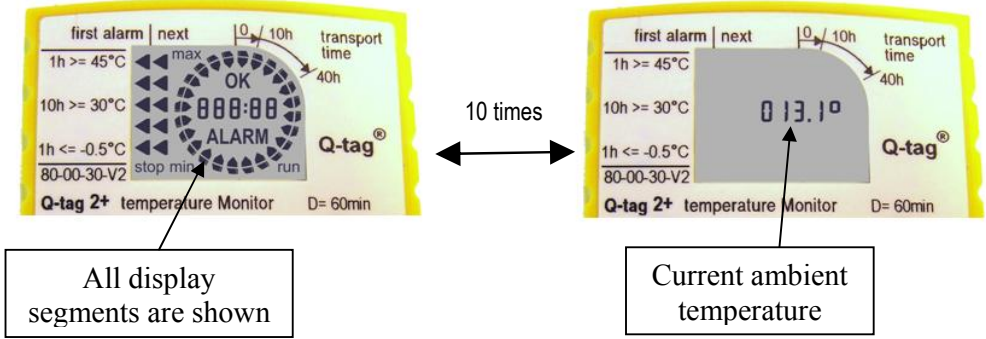

Important: Heating caused by hand contact may cause unduly high ambient temperatures to be displayed in **TEST** mode.

The Q-tag[®] 2 plus device automatically falls back to its prior operating mode after the tenth test cycle.

Battery

The Q-tag[®] 2 plus contains a CR Lithium battery. Please observe the following safety precautions.

- a. Dispose of or recycle the battery in accordance with your local regulations.
- b. Do not expose the device to extreme temperatures as this may lead to the destruction of the battery and could cause injury.
- c. Keep out of the reach of children.
- d. The end of the battery life is indicated by the expiry date printed on the backing card. Accuracy and proper function of the device cannot be assured beyond this expiry date.

VACCINE ARRIVAL REPORT (VAR)¹

This report is to be filled in by authorized staff, ratified by the Store Manager or the EPI Manager, and forwarded to the procurement agency within three days of vaccine arrival. Use one report for each vaccine in the shipment.

COUNTRY			
REPORT No.		Date of report	

Place, date and time of inspection	Name of cold store, date and time vaccines entered into cold store

PART I — ADVANCE NOTICE

MAIN DOCUMENTS	Date received by consignee	Copy airway bill (AWB)	Copy of packing list	Copy of invoice	Copy of release certificate
Pre-advice					
Shipping notification		Yes <input type="checkbox"/> No <input type="checkbox"/>	Yes <input type="checkbox"/> No <input type="checkbox"/>	Yes <input type="checkbox"/> No <input type="checkbox"/>	Yes <input type="checkbox"/> No <input type="checkbox"/>

List other documents (if requested)	
-------------------------------------	--

PART II — FLIGHT ARRIVAL DETAILS

AWB Number	Airport of destination	Flight No	ETA as per notification		Actual time of arrival	
			Date	Time	Date	Time

NAME OF CLEARING AGENT: _____ ON BEHALF OF: _____

PART III — DETAILS OF VACCINE SHIPMENT

Purchase Order No.	Consignee	Vaccine description (Type and doses/vial)	Manufacturer	Country

Vaccine				Diluent/droppers			
Lot Number	Number of boxes	Number of vials	Expiry date	Lot Number	Number of boxes	Number of units	Expiry date

(Continue on separate sheet if necessary)

	Yes	No	Comments
Was quantity received as per shipping notification?	<input type="checkbox"/>	<input type="checkbox"/>	
If not, were details of short-shipment provided prior to vaccine arrival?	<input type="checkbox"/>	<input type="checkbox"/>	

¹ Adopted from the Standard UNICEF Vaccine Arrival Report from WHO *Guidelines on the international packaging and shipping of vaccines* (WHO/IVB/05.23)

No. = Number

WHO recommends all UN agencies, countries and non-governmental organizations procuring vaccines adopt this report.

Report No.	
------------	--

PART IV — DOCUMENTS ACCOMPANYING THE SHIPMENT

Invoice	Packing list	Release certificate	Vaccine Arrival Report	Other
Yes <input type="checkbox"/> No <input type="checkbox"/>	Yes <input type="checkbox"/> No <input type="checkbox"/>	Yes <input type="checkbox"/> No <input type="checkbox"/>	Yes <input type="checkbox"/> No <input type="checkbox"/>	
Comments				

PART V — STATUS OF SHIPPING INDICATORS

Total number of boxes inspected:				
Coolant type:	Dry ice <input type="checkbox"/>	Icepacks <input type="checkbox"/>	No coolant <input type="checkbox"/>	
Temperature monitors present:	VVM <input type="checkbox"/>	Cold-chain card <input type="checkbox"/>	Electronic device <input type="checkbox"/>	Type: _____

PROVIDE BELOW DETAILS OF STATUS ONLY WHEN PROBLEMS ARE OBSERVED
 (in addition fill in ALARM REPORTING FORM if there are any ALARMS in electronic devices):

Box Number	LOT NO	Alarm in electronic device				Cold-chain monitor				Date/time of inspection
		>=45°C	>=30°C	>=10°C	<=-0.5°C	A	B	C	D	

(Continue on separate sheet if necessary)

PART VI — GENERAL CONDITIONS OF SHIPMENT

What was the condition of boxes on arrival?	
Were necessary labels attached to shipping boxes?	
Other comments including description of alarms in electronic devices: (continue on separate sheet if necessary).	

PART VII — NAME AND SIGNATURE

_____ DATE _____ DATE
 Authorized Inspection Supervisor Central store or EPI Manager

For Procurement Agency office use only
Date received by the office: _____ Contact person: _____

Guidelines for completing the Vaccine Arrival Report

The Vaccine Arrival Report (VAR) is a comprehensive record of cold-chain conditions during transport and of required compliance with shipping instructions. Recipient governments and procurement agencies (UNICEF country offices, UNICEF Supply Division, PAHO Revolving Fund), are responsible for the report, and for taking appropriate action if problems are reported (e.g. follow-up with the manufacturer, forwarding agent, WHO, etc.).

Use one report form for each shipment and for each vaccine in the shipment. In shipments containing diphtheria–tetanus–pertussis (DTP)–Hepatitis B (HepB) and *Haemophilus influenzae* type b (Hib) vaccines, use one form for DTP–HepB and a separate form for Hib. *In the case of short-shipments (where parts of the original quantities are not delivered), complete a separate report for each part delivered.*

Complete the form as described below. In the header boxes at the top of the form, enter the name of the recipient country, the report number, and details of place and date of inspection and storage. The report number is an internal number for organizing records; compile it as follows: country code; year; number for each report (e.g. BUR–2005–001 for one vaccine; BUR–2005–002 for a second vaccine, etc.). In the case of a short-shipment, the numbers for the separate deliveries would be, for example, BUR–2005–003.1, BUR-2005-003.2, etc.

Part I — Advance notice

- I.1 Enter dates and details of documents received in advance of the vaccine shipment.

Part II — Flight arrival details

- II.1 Fill in details of expected and actual arrival times for the shipment.
- II.2 Fill in the name a) of the clearing agent and b) for whom the agent acts (e.g. the Ministry of Health, UNICEF or WHO).

Part III — Details of vaccine shipment

- III.1 Fill in details of the order (purchase order number, consignee, vaccine description etc.).
- III.2 For each batch of vaccine included in the shipment, record:
- a) the number of shipping boxes;
 - b) the number of vials;
 - c) the expiry date.

The number of boxes you enter should always match the number of boxes shown in the packing list. If it does not, note under *Comments* if advance notice of a change in the quantity was provided. It is not necessary to count the number of individual vaccine packs in each shipping box for this report.

- III.3 For the diluents and droppers (if included) with each batch of vaccine in the shipment, record:
- a) the number of shipping boxes;
 - b) the number of vials;
 - c) the expiry date.

The information for III.2 and III.3 is also in the packing list.

Note: Diluents for freeze-dried vaccine and droppers for oral polio vaccine (OPV) are integral parts of the vaccine, so always include them on the same form. If diluent/droppers are delivered separately, consider it a short-shipment.

Part IV — Documents accompanying shipment

The packing list should indicate which box contains the shipping documents (usually Box 1).

- IV.1 If this information is not included in the packing list or in documents sent separately by courier, pouch or other means, note this under *Comments*.

- IV.2 Verify that all necessary documents are present and complete the form accordingly.

Note: If the lot release certificate is missing, do not use the vaccines; keep them on hold in cold storage

until the relevant document has been obtained from the vaccine manufacturer.

PART V — Status of shipping indicators

Inspect the temperature monitors in all boxes before putting vaccines into cold storage. For very large shipments, or when immediate storage in the shipping boxes is required, check a representative number of boxes before placing the shipment in the cold store. Complete inspection of all boxes the next day, or as soon as possible thereafter; under *Comments*, note the date and time when the complete inspection took place.

Note: In this report, enter the information below (V.1) *only* for boxes in which the temperature monitor shows a change that indicates potential damage to vaccines (alarm indication in the electronic device, or cold-chain monitor card as per vaccine/threshold table in card).

V.1 Enter:

- a) the number of boxes inspected (this should equal the total number in the shipment);
- b) the type of coolant used;
- c) details of any temperature exposure detected.

- V.2 Photocopy or scan LCD screens in electronic devices that show alarm status and attach to the report.

- V.3 Clearly identify vaccines in boxes in which the indicator shows exposure to temperatures that risk damage and keep them in the cold room for further assessment of their condition. **Do not discard vaccines until assessment is completed.**

PART VI — General conditions of shipment

- VI.1 Indicate if the shipping boxes were received in good condition and if all necessary labels on the outside of the shipping boxes were present; add any comments.

PART VII — Name and signature

- VII.1 The authorized person responsible for the inspection and the Central Store Manager or the EPI Manager should sign this report.

- VII.2 Send the form, completed and signed, to the procuring agency (UNICEF country office, Ministry of Health, or WHO country office) within three days of arrival of the vaccine.

Reporting ALARM details in international vaccine shipments

A special form has been designed for the purpose of reporting alarm details displayed in electronic devices. This form should ONLY be filled in if any alarms have occurred, and should be attached to the Vaccine Arrival Report (VAR). A clear photocopy and/or printed copy of the scanned image of the electronic devices displaying alarm status should be attached to this form.

ELECTRONIC DEVICE ALARM REPORT FORM

Country						Date of report					
Type of device	Q-tag 2 plus <input type="checkbox"/>	VaxAlert <input type="checkbox"/>	Type of vaccine								

Box no	Serial number	Time stopped	Elapsed transit time	>=45°C 1 hour		>=30°C 10 hrs		>=10°C 20 hrs		<=-0.5°C 1 hr	
				Time	°C	Time	°C	Time	°C	Time	°C

Use additional pages if necessary.

Guidelines for completing the Electronic Device Alarm Report Form

Country	Enter name of the country.
Date of report	Enter date of report.
Type of device	Mark the type of device by ticking the appropriate box.
Type of vaccine	Enter the type of vaccine, e.g. BCG, OPV, measles or DTP-HepB.
Box number	Write the number of the box (carton) that the electronic device was taken out of, e.g. 001, 002, ... 099.
Serial number	Write down the serial number of the electronic device from the bar code/serial number, e.g. 10000001 for Q-tag 2 plus, and W15908000245 for VaxAlert. Note that the serial numbers of the devices can be found on the front surfaces of the Q-tag 2 plus and on the side of the VaxAlert devices.
Time stopped	Enter the local time you stopped this particular device in 00hrs:00min format.
Elapsed transit time	Enter elapsed transit time.
Time	Enter time displayed in HISTORY mode for each alarm. For the Q-tag 2 plus the trigger time of the alarm is displayed as 000 hrs. 00 mins., e.g. 62:40 or 067:32. For VaxAlert devices the day is elapsed alarm time is displayed as days, hours, minutes. For all VaxAlert devices enter the time as 00(day):00(hr.):00(min.), e.g. 01:12:15 would mean that the alarm was triggered 1 day 12 hours and 15 minutes following activation.
°C	Enter minimum or maximum temperatures displayed for each alarm, e.g. 34.7°C, 13.5°C, or -4.5°C.

If any of the alarms are repeated in the same electronic device, enter this information in a new row.

SIMULATION

You have received a DTP-HepB shipment accompanied by electronic devices. In box Number 5 the device displayed ALARM status. Different alarm situations will be given in the following pages with explanations on how to carry this information on to the reporting form.



Country	<enter name of the country>		Date of report	<enter date>		
Type of device	Q-tag 2 plus <input checked="" type="checkbox"/>	VaxAlert <input type="checkbox"/>	Type of vaccine	DTP-HepB		

Box no	Serial number	Time Stopped	Elapsed transit time	>=45°C 1 hour		>=30°C 10 hrs		>=10°C 20 hrs		<=-0.5°C 1 hr	
				Time	°C	Time	°C	Time	°C	Time	°C
5	10000001	15:35	86:27			067:32	34.7			011:20	-4.2



HISTORY mode displaying the time of alarm triggering.

HISTORY mode displaying the maximum temperature recorded during violation.



HISTORY mode displaying the time of alarm triggering.

HISTORY mode displaying the minimum temperature recorded during violation.